

A16 MS



follow us on:



WWW.BOBSPA.COM

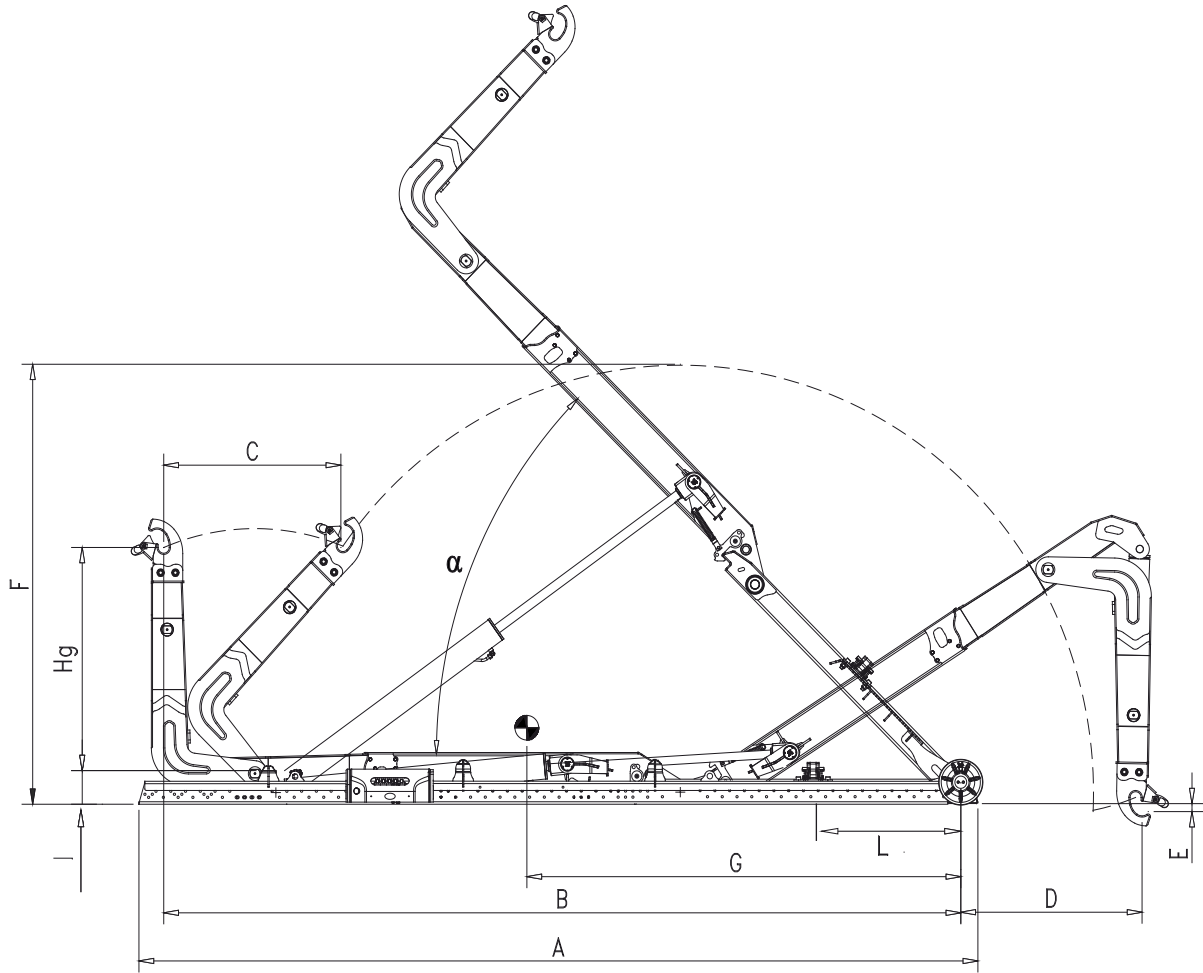

A16 MS

MODEL	HG	A	B	C	D	E	F	G	I	L	WEIGHT	α	CONTAINER	
													MIN	MAX
A16 C MS	1425/1570	5080	4600	1200	1660	160	2710	2640	220	500	1745 kg	55°	4000	5200
A16 NC MS	1425/1570	5280	4800	1200	1460	160	2710	2780	220	700	1770 kg	51°	4000	5400
A16 N MS	1425/1570	5480	5000	1200	1260	160	2710	2920	220	900	1795 kg	48°	4200	5600
A16 NL MS	1425/1570	5480	5200	1200	1420	50	2880	2960	220	900	1805 kg	48°	4400	5800
A16 L MS	1425/1570	5680	5400	1200	1220	50	2880	3100	220	1000	1810 kg	45°	4600	6000