

TA18 MS

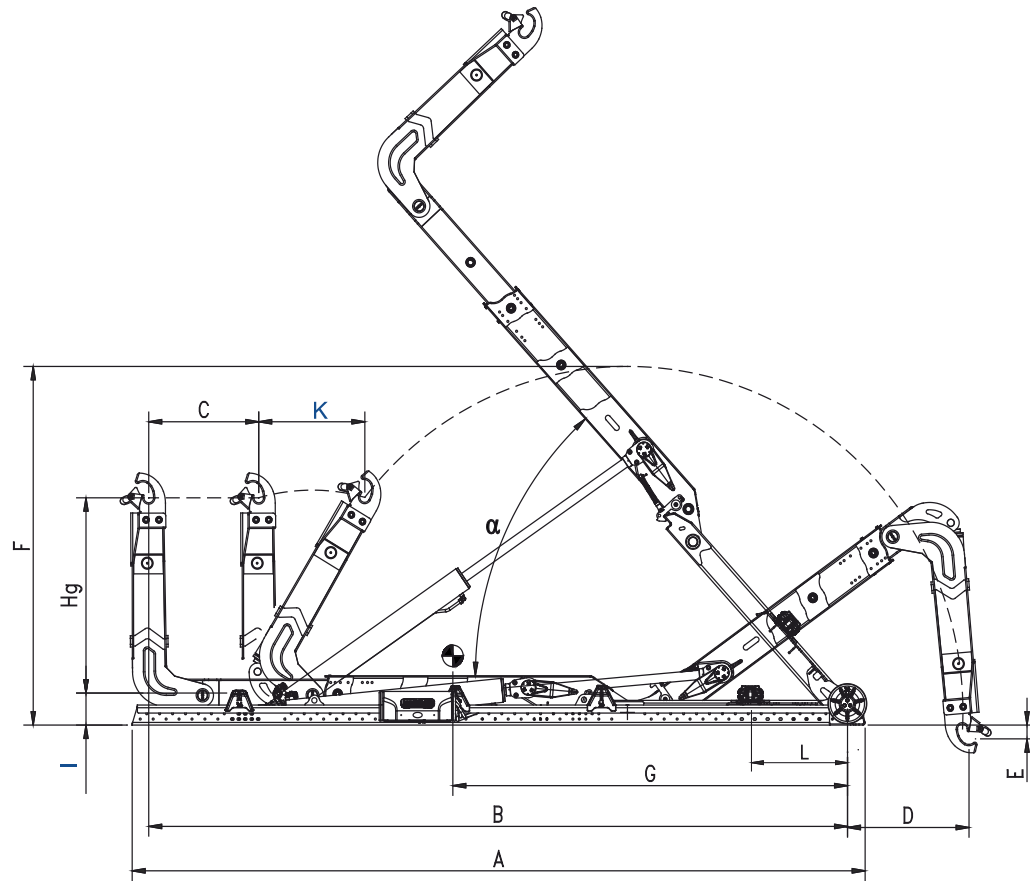

www.bobspa.com



TA18 MS													CONTAINER		
MODEL	HG	A	B	C	D	E	F	G	I	K	L	WEIGHT	α	MIN	MAX
TA18 C MS	1425/1570	5280	4800	650	1240	60	2680	2740	240	850	450	2230 kg	55°	3800	5400
TA18 NC MS	1425/1570	5280	5000	850	1240	60	2680	2770	240	850	450	2230 kg	55°	3800	5600
TA18 N MS	1425/1570	5480	5200	850	1040	60	2680	2910	240	850	550	2270 kg	51°	4000	5800
TA18 NL MS	1425/1570	5680	5400	850	940	60	2680	3050	240	850	750	2310 kg	48°	4200	6000
TA18 L MS	1425/1570	5880	5600	850	740	60	2680	3190	240	850	1000	2350 kg	45°	4400	6200

TAL18 MS													CONTAINER		
MODEL	HG	A	B	C	D	E	F	G	I	K	L	WEIGHT	α	MIN	MAX
TAL 18 C MS	1425/1570	6230	5750	1150	1340	100	2880	3210	220	850	550	2490 kg	57°	4200	6400
TAL 18 NC MS	1425/1570	6430	5950	1150	1140	100	2880	3360	220	850	750	2510 kg	54°	4400	6600
TAL 18 N MS	1425/1570	6630	6150	1150	940	100	2880	3510	220	850	1000	2530 kg	51°	4600	6800
TAL 18 NL MS	1425/1570	6830	6350	1150	740	100	2880	3660	220	850	1100	2550 kg	48°	4800	7000
TAL 18 L MS	1425/1570	7030	6550	1150	540	100	2880	3810	220	850	1300	2580 kg	46°	5000	7200