

TA 20 MS

EDIT 180620

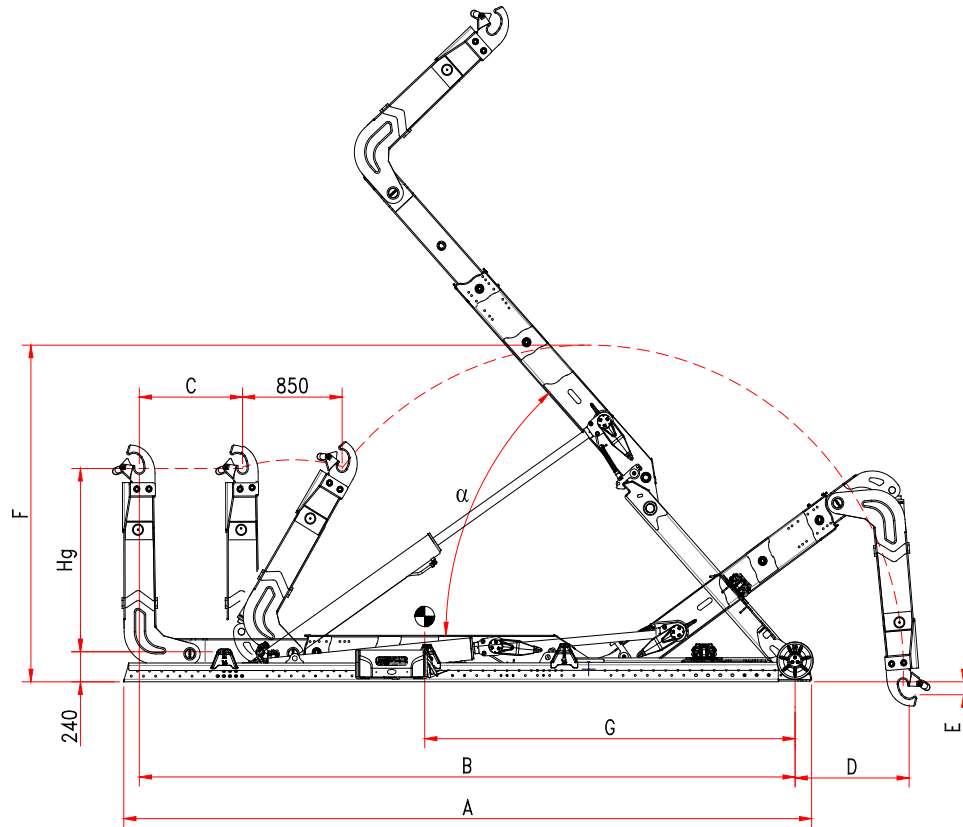

Model	Hg	A	B	C	D	E	F	G	Weight	α	Container	
											min.	max.
TA 20 C MS	1.425/1.570	5.280	4.800	650	1.240	60	2.680	2.740	2.270 kg	55°	3.600	5.400
TA 20 NC MS	1.425/1.570	5.280	5.000	850	1.240	60	2.680	2.770	2.270 kg	55°	3.600	5.600
TA 20 N MS	1.425/1.570	5.480	5.200	850	1.040	60	2.680	2.910	2.310 kg	51°	3.800	5.800
TA 20 NL MS	1.425/1.570	5.680	5.400	850	940	60	2.680	3.050	2.350 kg	48°	4.000	6.000
TA 20 L MS	1.425/1.570	5.880	5.600	850	740	60	2.680	3.190	2.390 kg	45°	4.200	6.200