

PRESS CONTAINERS

EDIT 220121

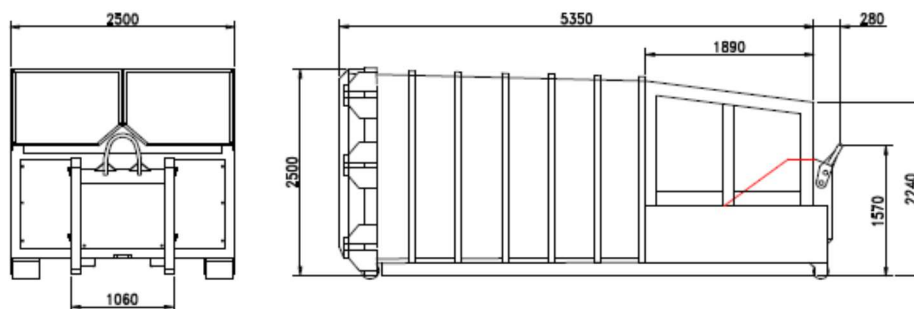

MAIN FEATURES

MODEL	CS 12	CS 16	CS 20	CS 24
CONTAINER CUBIC CAPACITY	12 m ³	16 m ³	20 m ³	24 m ³
TOTAL LENGTH	4.800 mm	5.600 mm	6.300 mm	7.000 mm
TOTAL WIDTH	2.200 mm	2.500 mm	2.500 mm	2.500 mm
TOTAL INNER HEIGHT (front – rear)	1.900 – 1.500 mm	2.050 – 2.170 mm	2.050 – 2.170 mm	2.050 – 2.170 mm
TOTAL WEIGHT	3.700 KG empty	4.750 KG empty	5.100 KG empty	5.450 KG empty
CHARGING HOPPER DIMENSIONS	2.080 x 1.900	2.080 x 1.900	2.080 x 1.900	2.080 x 1.900
POWER MOTOR TROPICALIZED	5,5 KW	7,5 KW (10 HP)	7,5 KW (10 HP)	7,5 KW (10 HP)
OIL TANK CAPACITY	150 l	150 l	150 l	150 l
WORKING PRESSURE	170 bar	200 bar	200 bar	200 bar
FEEDING	380 V three phase	380 V three phase	380 V three phase	380 V three phase
FREQUENCY	50 Hertz	50 Hertz	50 Hertz	50 Hertz
COMPACTING RATIO	35 Ton.	35/40 Ton.	35/40 Ton.	35/40 Ton.

Made of high quality steel

Reinforced conical structure

Electric control complete with buzzer and light signal for circuit start; stop and start button for compaction cycle; selector for one cycle or continuous work; emergency stop; indication light front – rear – safety – oil tank – compactor full.

Waterproof rear gate with mechanical screw type locking system

Additional rear gate towing hook

2 front and 2 rear rollers for compactor moving

Front hopper gates

Colour: one RAL colour to define

OPTIONS:

Oil cooling system

BOB CONNECT